

**SECTION A-A
 SCALE 1:2**

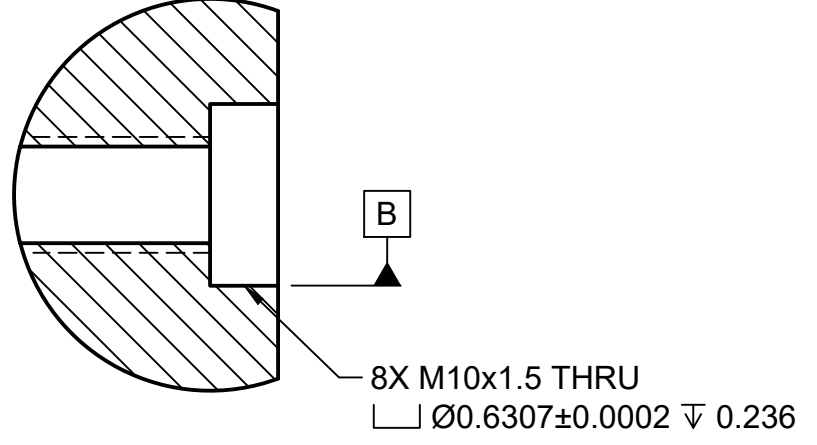

**DETAIL C
 SCALE 3:2**

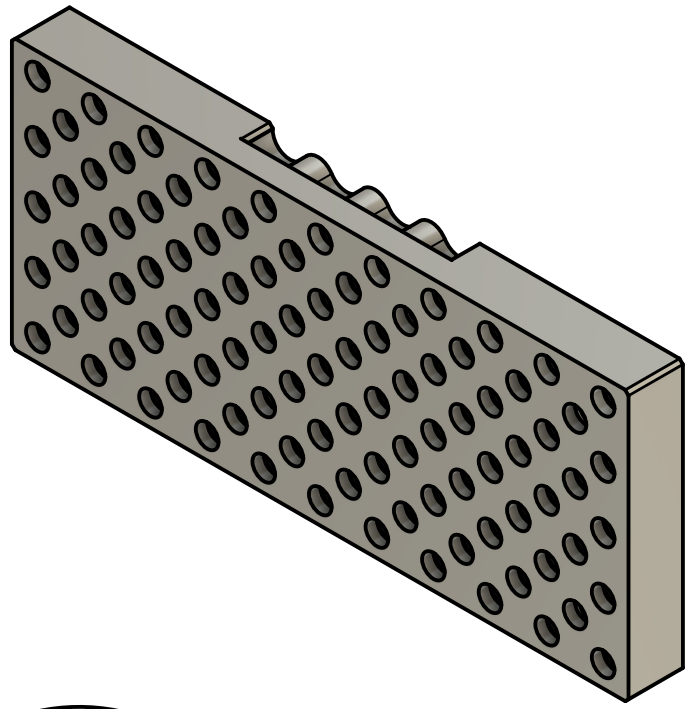
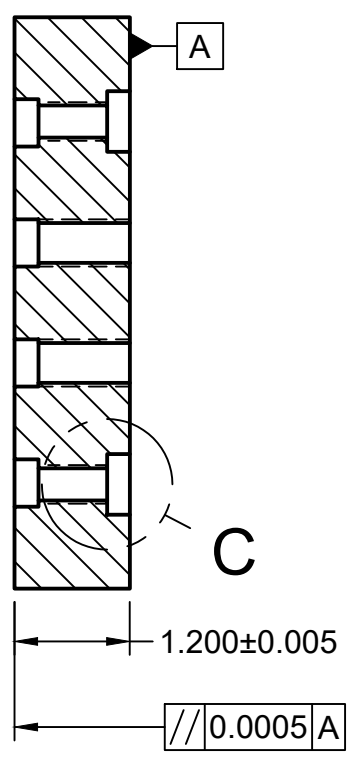
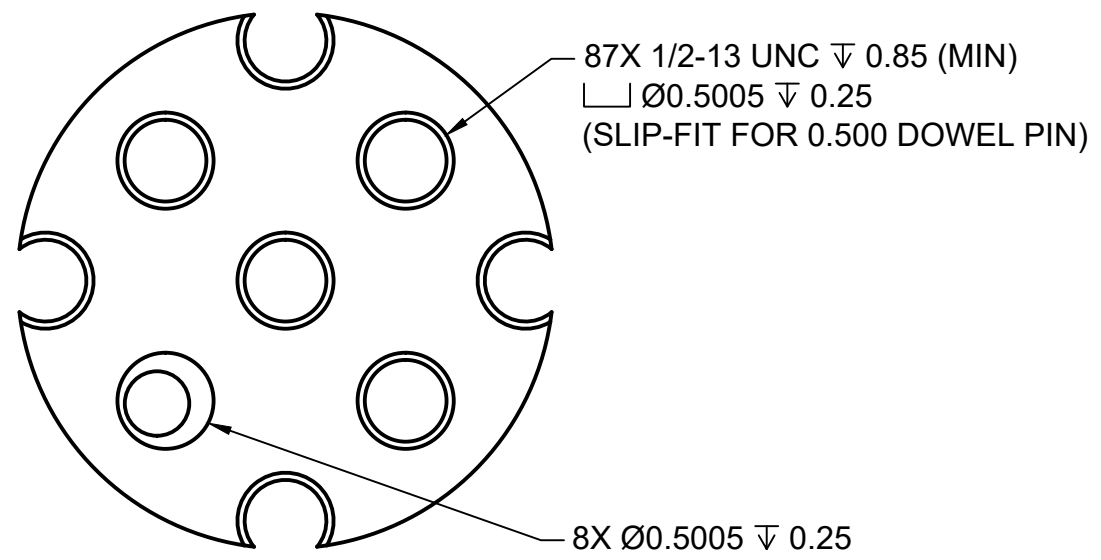

**DETAIL B
 SCALE 1:1**



ALL DIMENSIONS IN INCHES (UNLESS OTHERWISE SPECIFIED).
 Tolerances not listed subject to specifications on <https://saundersmachineworks.com/plate-tolerances>



PROJECT			
SMW Fixture Plates			
TITLE			
96mm Workholding Systems Top Plate			
14" x 6" x 1.25" 6061 Aluminum Pallet			
APPROVED	SIZE	CODE	DWG NO
CHECKED	B		S2145
DRAWN	Alex Pinson	1/9/2026	SCALE 1:2
WEIGHT		SHEET 1/1	
			REV
			1

*Given overhangs are based on the most recent machine table data made available to SMW. Always verify compatibility with your specific machine and generation.