

SECTION A-A  
 SCALE 2:3

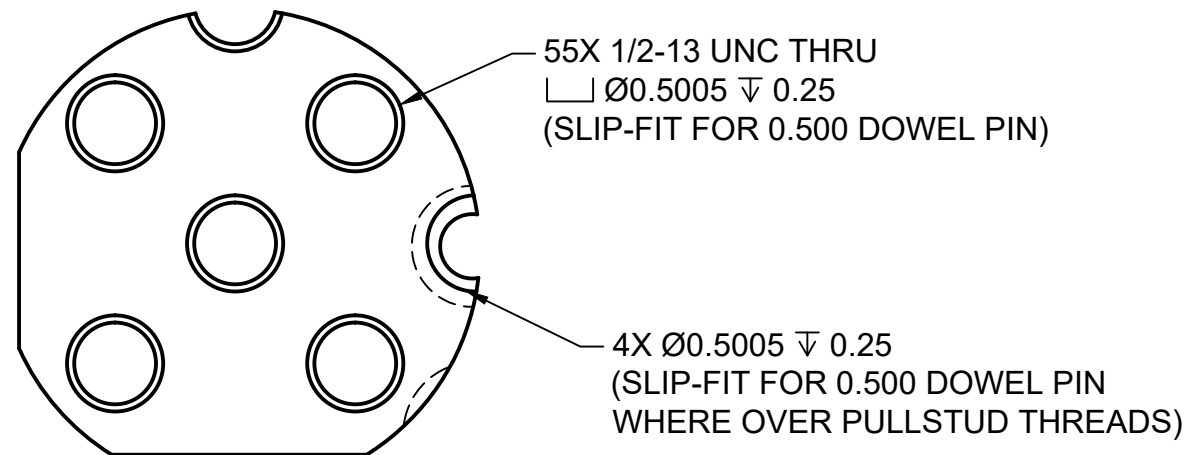
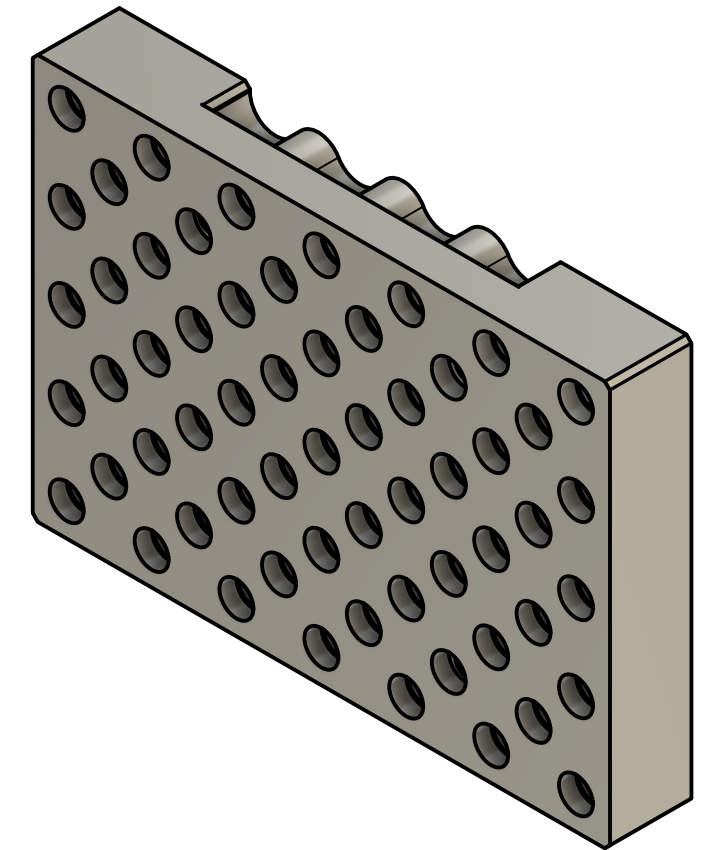
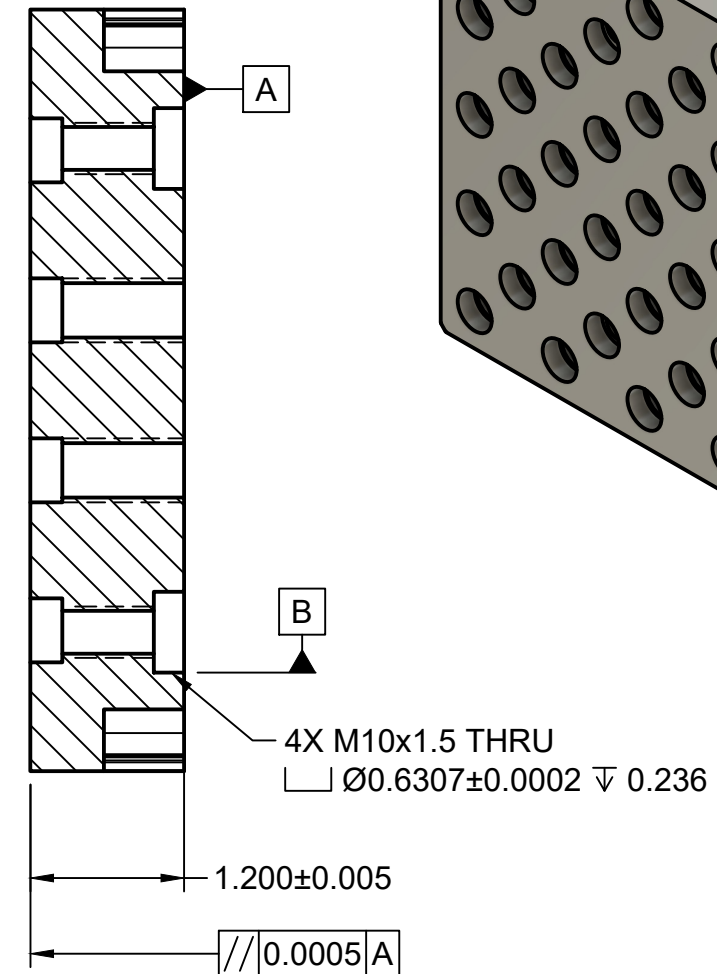

DETAIL B  
 SCALE 1:1

\*Given overhangs are based on the most recent machine table data made available to SMW. Always verify compatibility with your specific machine and generation.

ALL DIMENSIONS IN INCHES (UNLESS OTHERWISE SPECIFIED).  
 Tolerances not listed subject to specifications on <https://saundersmachineworks.com/plate-tolerances>



		PROJECT		
		SMW Fixture Plates		
APPROVED CHECKED		TITLE		
		96mm Workholding Systems Top Plate		
DRAWN Alex Pinson 1/29/2026		8" x 6" x 1.25" 6061 Aluminum Pallet		
		SIZE	CODE	DWG NO
SCALE 2:3		B	S2144	REV 1
		WEIGHT		SHEET 1/1