

9.613

0.476

0.000

0.000

0.394

19.685

0.85

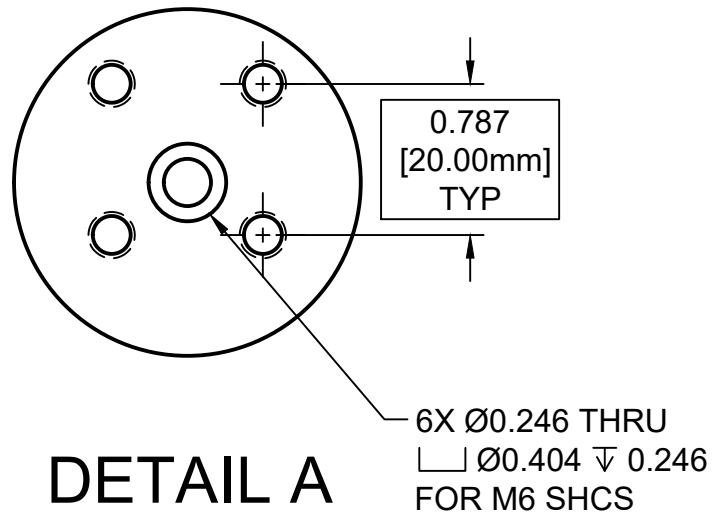
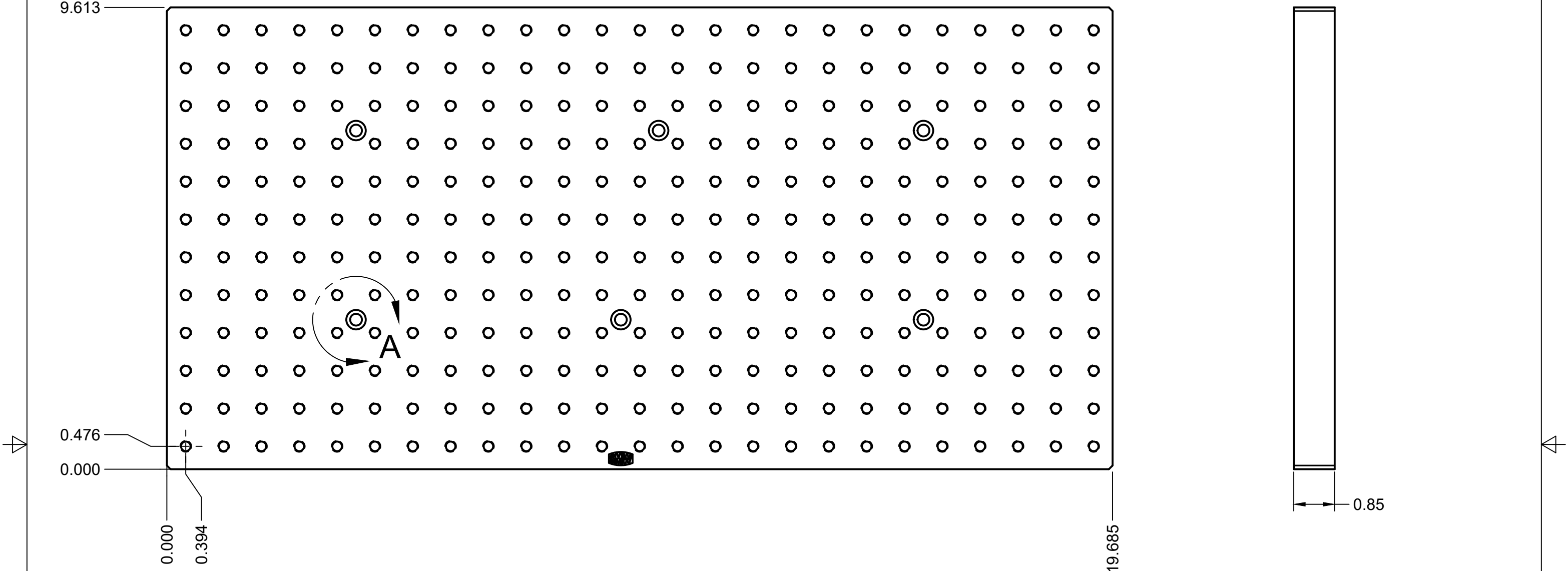

DETAIL A  
SCALE 1:1

ALL DIMENSIONS IN INCHES (UNLESS OTHERWISE SPECIFIED).

Tolerances not listed subject to specifications on <https://saundersmachineworks.com/pages/fixture-plate-faq>



PROJECT			
SMW Fixture Plates			
TITLE			
Samurai Machine Tools			
120i			
19.7" x 9.6" 6061 Aluminum Fixture Plate			
APPROVED	SIZE	CODE	DWG NO
CHECKED	B		S1799
DRAWN Alex Pinson	6/21/2023	SCALE 1:8	WEIGHT
SHEET 1/2			REV 1

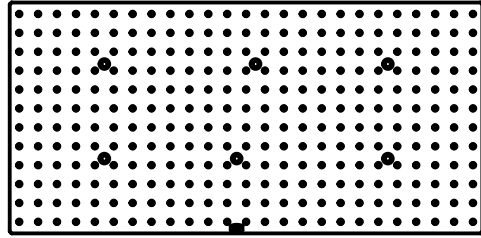

ALL DIMENSIONS IN INCHES (UNLESS OTHERWISE SPECIFIED).

Tolerances not listed subject to specifications on <https://saundersmachineworks.com/pages/fixture-plate-faq>



PROJECT			
<b>SMW Fixture Plates</b>			
TITLE			
<b>Machine Brand Machine Model</b>			
XX" x XX" x XX" 6061 Fixture Plate			
APPROVED	SIZE	CODE	DWG NO
CHECKED	B		
DRAWN Alex Pinson 6/21/2023	SCALE 1:8	WEIGHT	SHEET 2/2
			REV 1