

///0.0005 / 18 A

0.95^{+0.01}_{-0.04}

A

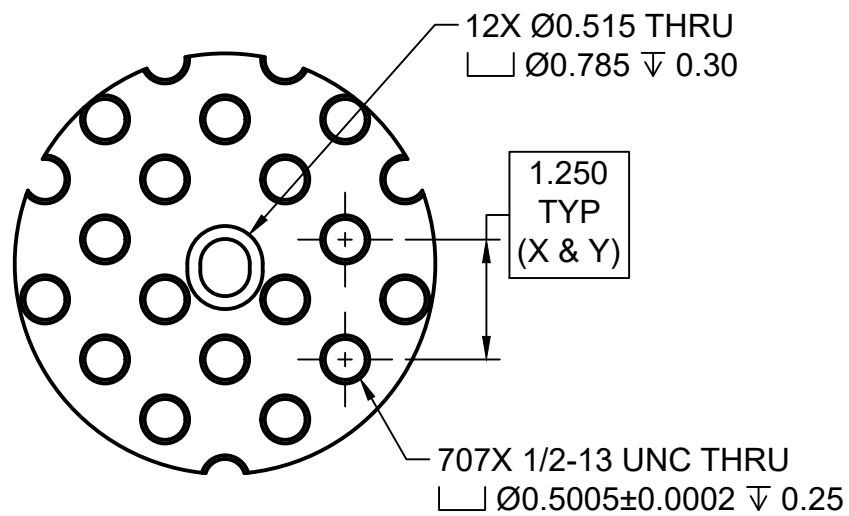

DETAIL A
SCALE 1:2

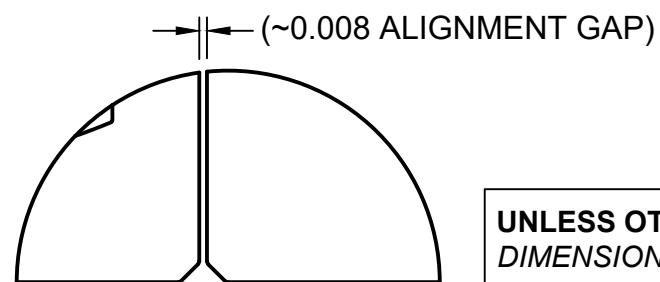

DETAIL B
SCALE 5:1

UNLESS OTHERWISE SPECIFIED:
DIMENSIONS ARE IN INCHES

GENERAL TOLERANCES ARE:
X.XX = ± 0.01
X.XXX = ± 0.005

PROJECT

SMW Fixture Plates

TITLE

Universal
Knee Mill

51" x 12" Fixture Plate Set



APPROVED

CHECKED

DRAWN

Alex Pinson

11/15/2024

SIZE

B

CODE

DWG NO

WEIGHT

SHEET 1/1

REV

1